

SHELVES FOR 36" AND UNDER BOX
WILL NOT HAVE RETURN LIP

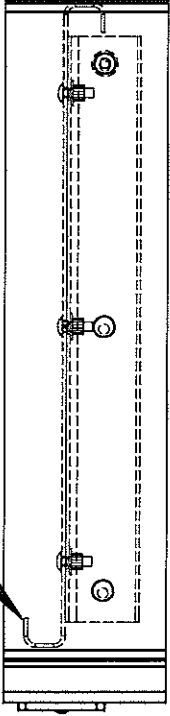

DETAIL A
SCALE 1:6

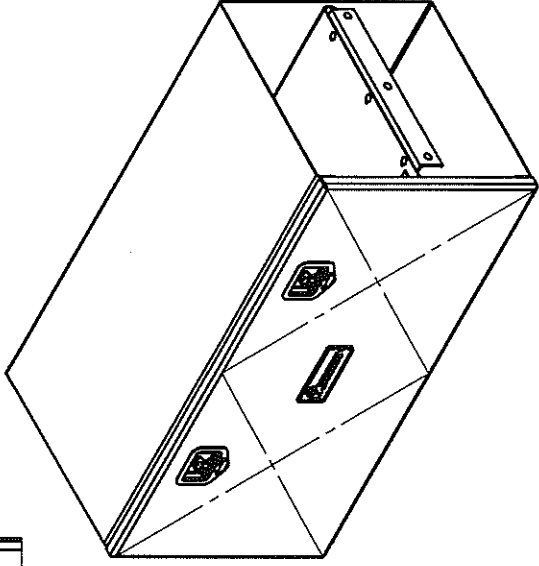
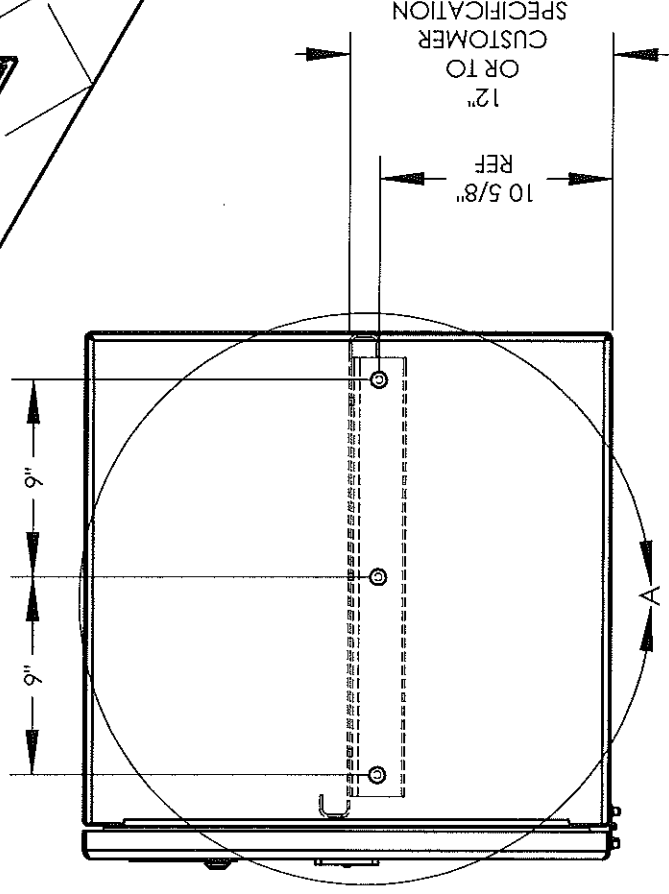

SHOWN WITH END REMOVED

INSTRUCTIONS ARE
FOR SHELVES #
2424
2430
2436
2448
2460

- 1) DETERMINE THE LOCATION AND ORIENTATION OF THE SHELF (SHELF MAY BE MOUNTED WITH THE LIP UP OR THE LIP DOWN.)
- 2) DRILL 1 1/32" HOLES IN THE TOOL BOX ENDS. HOLE SIZE IS CRITICAL FOR BOLT SEATING.
- 3) MOUNT ANGLES TO THE TOOL BOX END USING CARRIAGE BOLTS.
- 4) INSERT SHELF AND MOUNT TO ANGLES USING CARRIAGE BOLTS.
- 5) TORQUE ALL NUTS TO 19 FT. LBS.
- 6) PERIODICALLY CHECK AND MAINTAIN TORQUE ON ALL NUTS.

F	2	87-9900-284	ANGLE, 24"D TOOL BOX SUPPORT
E	1	REF	SHELF, TOOL BOX
D	12	11-2010	NUT, 5/16"-24 NYLON LOCK NUT
C	12	11-7035	WASHER, 5/16" SAE WASHER
B	12	11-8241	5/16" X 1" CARRIAGE BOLT
A	1	REF	24"D TOOL BOX
ITEM QTY.		PART NUMBER	DESCRIPTION
DATE	DESCRIPTION	BY	SCALE NONE
			DWN BY: TPK
			REF #
			WEIGHT
			DATE 2/25/08
			DWG LRSDD0101
			REV

REV	DATE	DESCRIPTION	BY	SCALE NONE
				DWN BY: TPK
				REF #
				WEIGHT
				DATE 2/25/08
				DWG LRSDD0101
				REV

MERRITT EQUIPMENT CO.
2339 HWY 86 HENDERSON, COLORADO 80640 T (800) 533 0187

TITLE 24"D BOLT IN SHELF
MOUNTING INSTRUCTIONS